

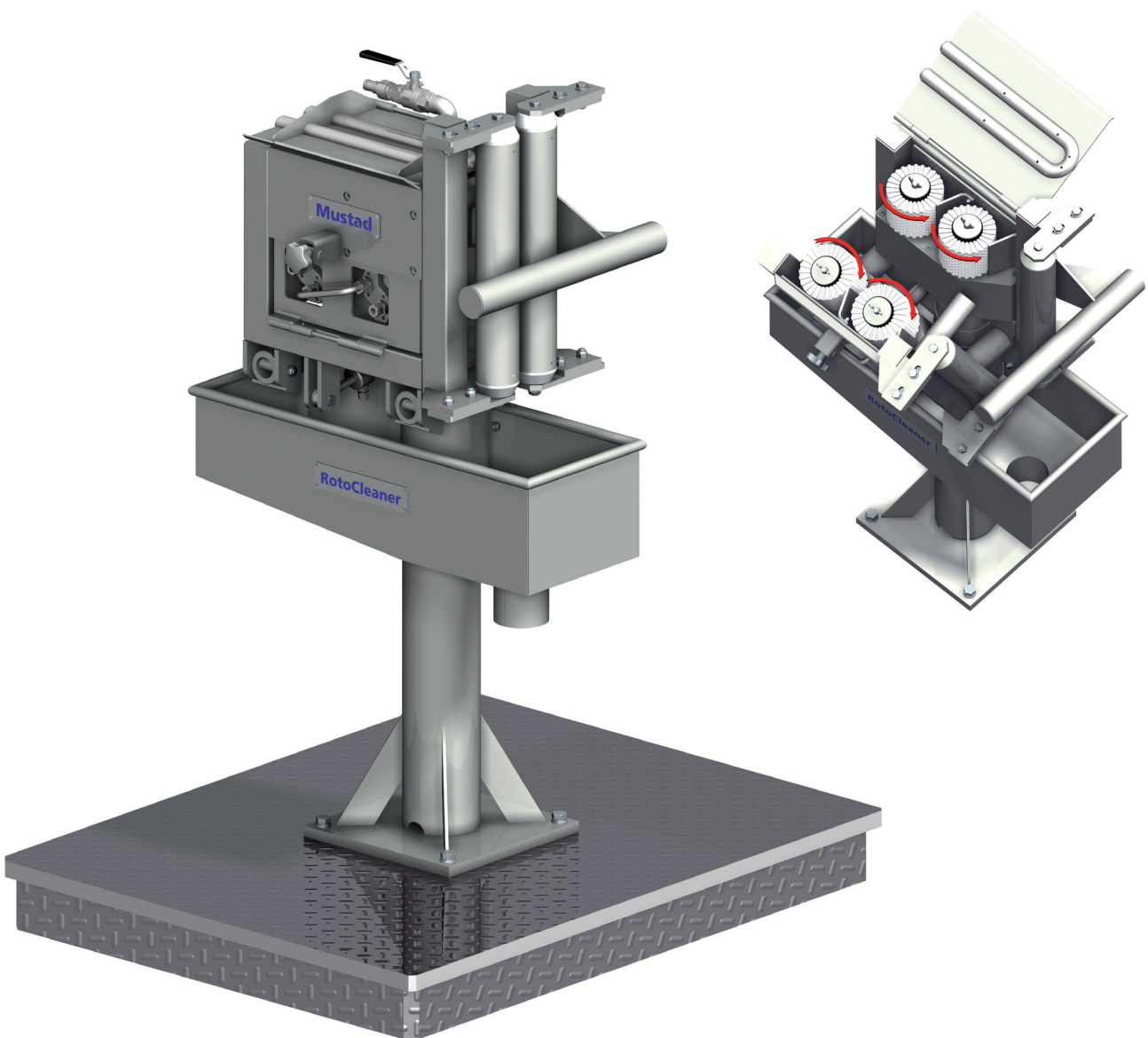

Mustad
- A better way to fish

AUTOLINE™ DEEP SEA SYSTEM

RotoCleaner™





AUTOLINE™ DEEP SEA SYSTEM

RotoCleaner™

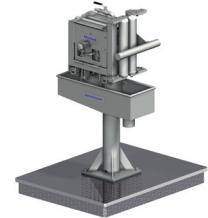

The new RotoCleaner™ is Mustad Longline's last generation hook cleaner, and the recommended solution. The RotoCleaner™ cleans the hooks perfectly, even when using bait fish with heavy leathery skin. Rotating brushes will clean the hooks and let the line go through without damaging fibers.

Increased productivity

This last generation hook cleaner will increase productivity by:

- Increasing the functionality of the hook separator
- Reducing numbers of stops during hauling
- Lengthening life span of the fishing line
- Less wear on the sheaves for main hauler and hook separator
- Increasing numbers of hooks set and hauled per day
- Reducing consumption of replacement brushes. Expected annual maintenance cost of approx. \$600 compared to approx. \$4000 on standard hook cleaner
- Less work at the hook separator is giving better working condition for the crew

Fits most haulers

RotoCleaner is produced from solid stainless steel, driven by a longlife hydraulic motor and ruggedized PLC control. The Mustad Longline RotoCleaner can easily be fitted to most haulers, both low and high pressure.

Rotating brushes and water jets

Hooks passes by the "fish stripper" and are cleaned by 4 rotating brushes combined with high pressure water jets. Hydraulic motors are connected in series with the main hauler and the hook separator which automatically coordinates start and stop with the two other units. The hook cleaner is easily opened and closed by a maneuvering valve strategic positioned at the hauling station. Hydraulic power is drawn from existing power pack supplying the hook separator and line retriever units.

Better cleaning

We replaced our existing hook cleaner with Mustad Longline's new RotoCleaner, to obtain a better cleaning of remaining bait from the hooks. The result has absolutely been as expected. The rotating hook cleaner clean the hooks and ground line much better, while the wear of the mainline is reduced significantly. The effect is less labour-intensive hook separation, less wear of hauler and separator sheaves and increased lifetime of the lines. This has definitely been a profitable investment for us.

*Mr. Kjell-Gunnar Hoddevik
Owner and Captain, M/S Atlantic*

Mustad
- A better way to fish





AUTOLINE™ DEEP SEA SYSTEM

RotoCleaner™

Technical Specifications:

Weight: 180 kg (400 lbs.)

Hydraulic motor: 80 ccm (4.88 in³) 4 pcs.
Motor speed: 30 rpm
Pressure drop: 90 bar (1300 psi)
Oil flow: 8 liter/min (2,1 gallons/min)

Hydraulic cylinder:

Pressure drop: 15 bar (210 psi)
Oil flow: 1 liter/min (0,26 gallons/min)

High pressure water pump:

Electric power: 3 kW 3 x 220/440V 50 Hz - 60 Hz
Weight: 41 kg (90 lbs)

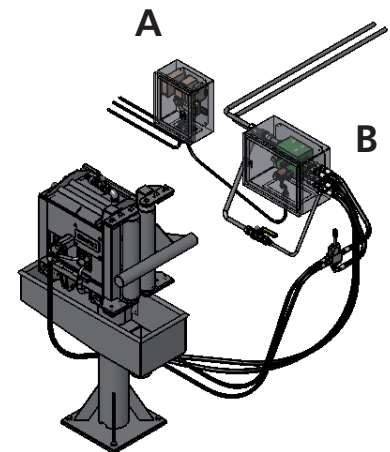

A: CONTROL BOX PLS/ELECTRIC:
H=300, B=250, D=160

B: CONTROL CABINET HYDRAULIC:
H=300, B=380, D=210

Mustad
- A better way to fish

